

Vehicle Standards Information



18

Rev 2, Oct 2003
Supersedes
VSI 18 Rev 1 May 98

Dimension and mass limits for vehicle combinations

Dimension Limits

The dimension limits shown below apply to vehicles in combination. The operation of a vehicle combination that does not comply with these limits is illegal unless a permit is issued by the Roads and Traffic Authority (RTA). Refer also to Vehicle Standards Information (VSI) No. 5 for more information on vehicle dimension limits.

Note: For the purpose of this publication, any towed vehicle is referred to as a trailer.

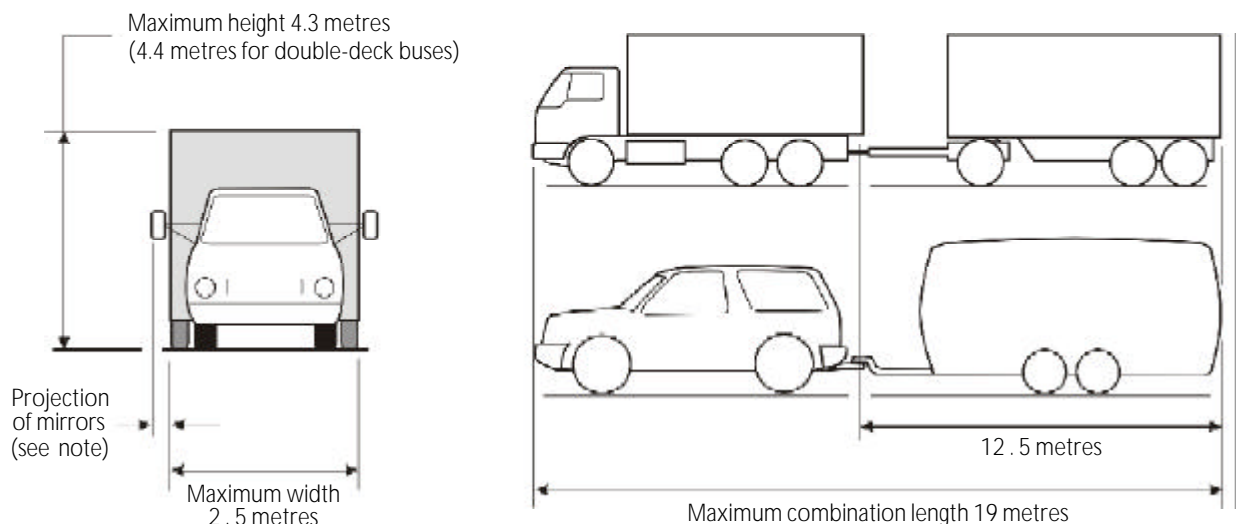

Note: Where the trailer is wider than the towing vehicle, side mirrors on the towing vehicle may project beyond the extreme width of the trailer. However, when the trailer is detached, these mirrors must be removed if they project more than 150mm beyond the extreme width of the towing vehicle. [In the case of vehicles of more than 3.5 tonnes Gross Vehicle Mass (GVM), collapsible mirrors may project up to 230mm beyond the width of the vehicle provided they are capable of collapsing to 150mm].

Mass Limits

Combinations including a towing vehicle with a GVM up to 4.5 tonnes

The laden mass of the trailer must not exceed:

- The capacity of the towing attachment (the towbar), or
- the maximum laden mass of the trailer, or
- the maximum towing mass specified by the manufacturer of the towing vehicle.

Where the manufacturer of the towing vehicle has not specified the maximum towing mass, the following maximum towing mass applies:

- $1\frac{1}{2}$ times the unladen mass of the towing vehicle, providing the trailer is fitted with brakes that are working properly, or
- the unladen mass of the towing vehicle.

The mass of any combination must not exceed:

- The towing vehicle's Gross Combination Mass (GCM).

Combinations including a towing vehicle with a GVM in excess of 4.5 tonnes

The mass of any laden trailer must not exceed:

- The maximum laden mass of the trailer, and
- for a dog trailer or pig trailer, the loaded mass of the towing vehicle.

The mass of any combination must not exceed:

- The towing vehicle's Gross Combination Mass (GCM), and
- 42.5 tonnes for a combination other than a Road Train or B-Double.

Note: The GVM/GCM of a vehicle registered in NSW before January 1995 is its aggregate weight.

Manufacturers Ratings

The manufacturers ratings on components such as wheels, tyres, axles, suspension, couplings, etc. must not be exceeded.

Permits

If a vehicle combination exceeds any of the mass or dimension limits specified above, then an overdimension or overmass permit is required before the combination may be driven on the road. Refer to the *"Operators Guide to Oversize and Overmass Vehicle Movements"*.

Information about overdimension and overmass permits can be obtained from:

| | |
|--------------------------------|---|
| RTA Permits Unit | Tel: (02) 9218 6221, or |
| Ground Floor, Centennial Plaza | 1800 677 583 (if calling from outside Sydney Metropolitan area) |
| 260 Elizabeth Street | Fax: (02) 9218 6564 |
| Surry Hills NSW 2010 | |



Further information:



Tel: 1300 137 302

Fax: (02) 9843 3821



www.rta.nsw.gov.au

Email: tech-enq@rta.nsw.gov.au



RTA Technical Enquiries

PO Box 1120 PARRAMATTA NSW 2124